

**NEW!**

## ENGINE

Model	: ISUZU-6HK1X
Type	: Water-cooled, 4 cycle, 6 cylinders, line type direct injection, turbocharger, intercooler, electronic diesel engine
Power	: 281 HP (210 kW) @1900 rpm / SAE J1995 (Gross)
Max. Torque	: 1080 Nm @1500 rpm (Gross)
Displacement	: 7790 cc
Bore and Stroke	: 115 mm x 125 mm
Emission Class	: EU: Stage V

## UNDERCARRIAGE

X Type Lower Frame Construction Pentagon Box Type Chassis	
Shoe	: Triple grouser
No. Of Shoes	: 2 x 50
No. Of Lower Rollers	: 2 x 9
No. Of Upper Rollers	: 2 x 2
Full Trackguard	: Complete
Track Tensioning	: Hydraulic Spring Tensioning

## CAB

- Improved operator's all round visibility
- Increased cabin internal space
- Use of six viscomount cabin mountings that dampen the vibrations
- High capacity A/C
- High resolution, led backlight, color LCD display
- Opera Control System
- Cooled storage room
- Glass holder, book and object storage pockets
- Pool type floor mat
- Improved operator's comfort through versatile adjustable seat
- Ergonomically redesigned cabin through relocated switch board, and re-styled travel pedals and joysticks.
- FOPS2 upper cabin protection (Standard in countries with CE requirements).

## TRAVEL AND BRAKERS

Travel	: Fully hydrostatic
Travel Motors	: Axial piston type
Reduction	: 2 stage planetary gear
<b>Travel Speed</b>	
High Speed	: 5,0 km/h
Low Speed	: 2,9 km/h
Max. Drawbar Pull	: 30.470 kgf
Gradeability	: 35° (%70)
Parking Brake	: Hydraulic multi disc type
Ground pressure	: 0,72 kgf/cm <sup>2</sup>

## LUBRICATION

Centralized lubrication system is provided for lubrication all difficult-to-reach parts on the components, such as boom and arm

## HYDRAULIC SYSTEM

<b>Main Pump</b>	
Type	: Double variable displacement axial piston pumps
Max. Flow	: 2 x 300 L/min
Pilot Pump	: Gear, 28,5 L/min
<b>Relief Valves</b>	
Attachment	: 350 kgf/cm <sup>2</sup>
Power Boost	: 380 kgf/cm <sup>2</sup>
Travel	: 350 kgf/cm <sup>2</sup>
Swing	: 285 kgf/cm <sup>2</sup>
Pilot	: 40 kgf/cm <sup>2</sup>
<b>Cylinders</b>	
Main Boom	: 2 x ø 145 x ø 100 x 1.510 mm
Stick Cylinder	: 1 x ø 170 x ø 120 x 1.735 mm
Bucket Cylinder	: 1 x ø 145 x ø 105 x 1.280 mm

## OPERA CONTROL SYSTEM

- Easy-to-use control panel and menu
- Improved fuel economy and productivity
- Maximum efficiency by selection of power and work modes
- Overheat prevention and protection system without interrupting the work
- Automatic powerboost switch-on and switch-off
- Automatic electric power-off
- Maintenance information and warning system
- Error mode registry and warning system
- Ability to adjust hydraulic flow from Opera screen
- Maintenance information and warning system
- Automatic powershift to improve performance
- Selection of multi-language on control panel.
- Real time monitoring of operational parameters such as pressure, temperature, engine load
- Anti-theft system with personal code
- Possibility to register 26 different operating hours
- Rear-view, arm-view camera (Optional)
- Hidromek Smartlink (Optional)

## SWING SYSTEM

Swing Motor	: Axial piston type integrated with shock absorber valves
Reduction	: 2 stage planetary gear box.
Swing Brakes	: Hydraulic multi disc type, automatic warnings
Swing Speed	: 9,4 rpm

## CAPACITY

Fuel Tank	: 565 L	Engine Oil	: 44 L
Hydraulic Tank	: 265 L	Radiator	: 55 L
Hydraulic System	: 470 L	Urea tank	: 70 L

## ELECTRICAL SYSTEM

Voltage	: 24 V
Battery	: 2 x 12 V / 150 Ah
Alternator	: 24 V / 50 A
Starting Motor	: 24 V / 5 kw

## OPERATING WEIGHT

Standard machine operating weight : 40.400 kg

Operational weight, complying with the ISO 6016 standards, includes full fuel tank, hydraulic system and other liquids, 75 kg operator weight and standard equipped machine weight. Optional equipments are not included.

# HMK 390H6 H4

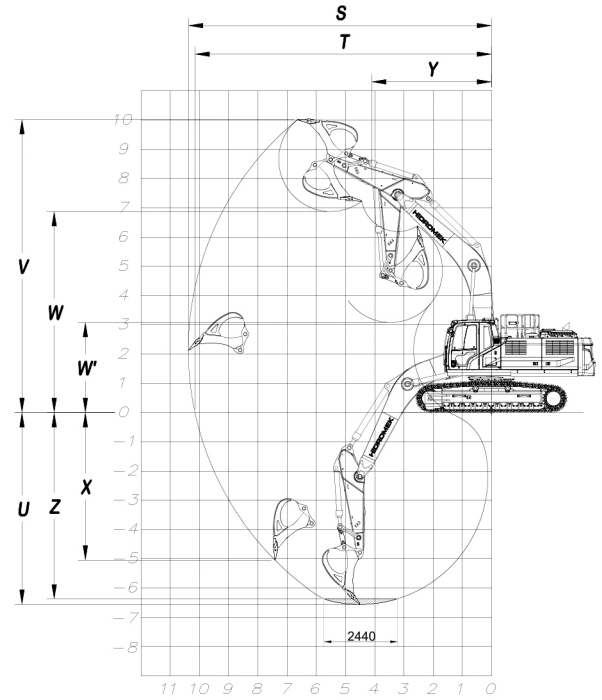
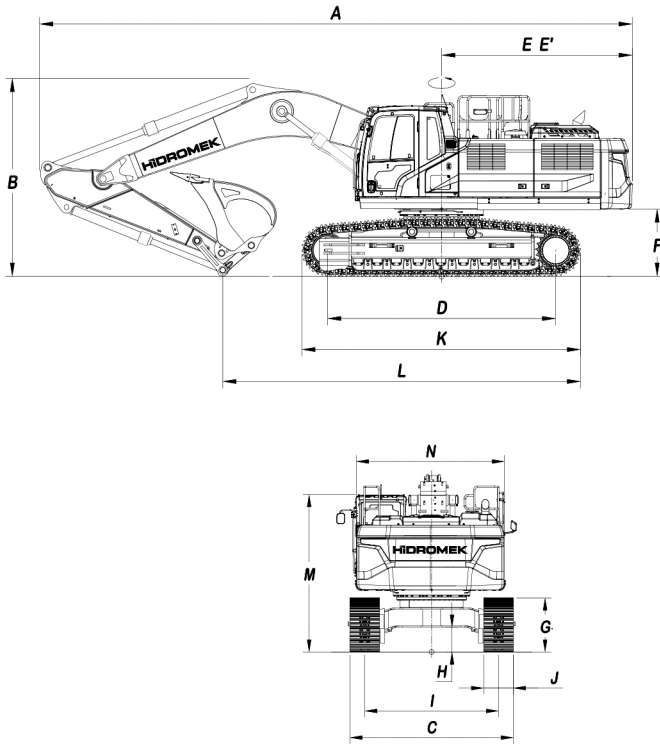

## GENERAL DIMENSIONS

Boom Dimension	6.100 mm		6.500 mm	
Arm Dimension	*2.600 mm	2.600 mm	3.200 mm	4.000 mm
A - Overall length	10.920 mm	11.410 mm	11.380 mm	11.400 mm
B - Overall height of boom	3.640 mm	3.510 mm	3.510 mm	3.720 mm
C - Overall width	3.300 mm			
D - Tumbler distance	4.240 mm			
E - Rear end length	3.585 mm			
E' - Tail swing radius	3.540 mm			
F - Counterweight clearance	1.250 mm			
G - Crawler height	1.090 mm			
H - Minimum ground clearance	500 mm			
I - Track gauge	2.700 mm			
J - Shoe width	600 mm			
K - Crawler length	5.190 mm			
L - Length on ground	6.670 mm	7.140 mm	6.200 mm	5.550 mm
M - Cab height	3.190 mm			
N - Upperstructure width	2.990 mm			

\* Standard

## WORKING DIMENSIONS

Boom Dimension	6.100 mm		6.500 mm	
Arm Dimension	*2.600 mm	2.600 mm	3.200 mm	4.000 mm
S - Max. digging reach	10.380 mm	10.720 mm	11.320 mm	12.030 mm
T - Max. digging reach on ground	10.150 mm	10.500 mm	11.120 mm	11.840 mm
U - Max. digging depth	6.560 mm	6.970 mm	7.570 mm	8.370 mm
V - Max. cutting height	10.020 mm	10.010 mm	10.460 mm	10.680 mm
W - Max. dumping height	6.870 mm	6.950 mm	7.330 mm	7.580 mm
W' - Min. dumping height	3.070 mm	3.320 mm	2.740 mm	1.950 mm
X - Max. vertical wall digging depth	5.050 mm	5.000 mm	5.900 mm	6.520 mm
Y - Min. front swing radius	4.110 mm	4.480 mm	4.500 mm	4.620 mm
Z - Maximum Digging Depth (2440 mm level)	6.380 mm	6.770 mm	7.410 mm	8.230 mm

## DIGGING PERFORMANCE

Standard Bucket Capacity (SAE)	2,2 m <sup>3</sup>
Bucket digging force (power boost) ISO	23.300 (25.300) kgf
Arm breakout force (power boost) ISO	20.400 (22.100) kgf



## HIDROMEK

### FACTORY - HEAD OFFICE

Ahi Evran OSB Mahallesi Osmanlı Caddesi No:1 06935 Sincan / ANKARA / TÜRKİYE  
 Tel: (+90) 312 267 12 60 Fax: (+90) 312 267 12 39  
 www.hidromek.com

**Notice:**  
 Hidromek has the right to modify the specifications and design of the model indicated on this brochure without prior notice.