

H4 SERIES

HMK 360 LC



HIDROMEK

360

HMK 360 LC

HIDROMEK





Innovation coming from experience: H4 Series

Being produced with developed hydraulic system design, HIDROMEK's H4 Series excavators offer an outstanding performance by working fast, productively and efficiently. H4 Series excavators produce more work with less fuel; hence, they are more profitable for the users.

H4
SERIES

Performance.....	6-7
Durability.....	8-11
Safety.....	12-13
Technology.....	14-15
Comfort.....	16-17
HIDROMEK Smartlink - Ease of Service.....	18-19
Technical Features	20-24

The information and images, and equipment presented in this brochure are either standard or optional depending on the configuration. HIDROMEK has the right to modify the specifications and the designs of the model indicated in this brochure without prior notice.





ATTENTION
AVANT D'UTILISER LE MATÉRIEL METTEZ
LE ROBINET À VOS BRAS À LA POSITION "ARRÊTÉ"
SI NON, LE MATÉRIEL PEUT ÊTRE ENDOMMAGÉ



Takes productivity to the next level!

HMK 360 LC crawler excavator provides high performance with its powerful engine and dynamics structure. Thanks to its boom and arm structure and earthmoving type bucket, it offers advantages especially in earthmoving works, digging and loading operations, and increases work efficiency to a higher level.

HMK 360 LC makes a difference in earthmoving!

HMK 360 LC makes a difference with its high performance in all kinds of works such as earthmoving, area arrangement, construction site preparations etc. through its tonnage, boom-arm length and earthmoving type bucket.





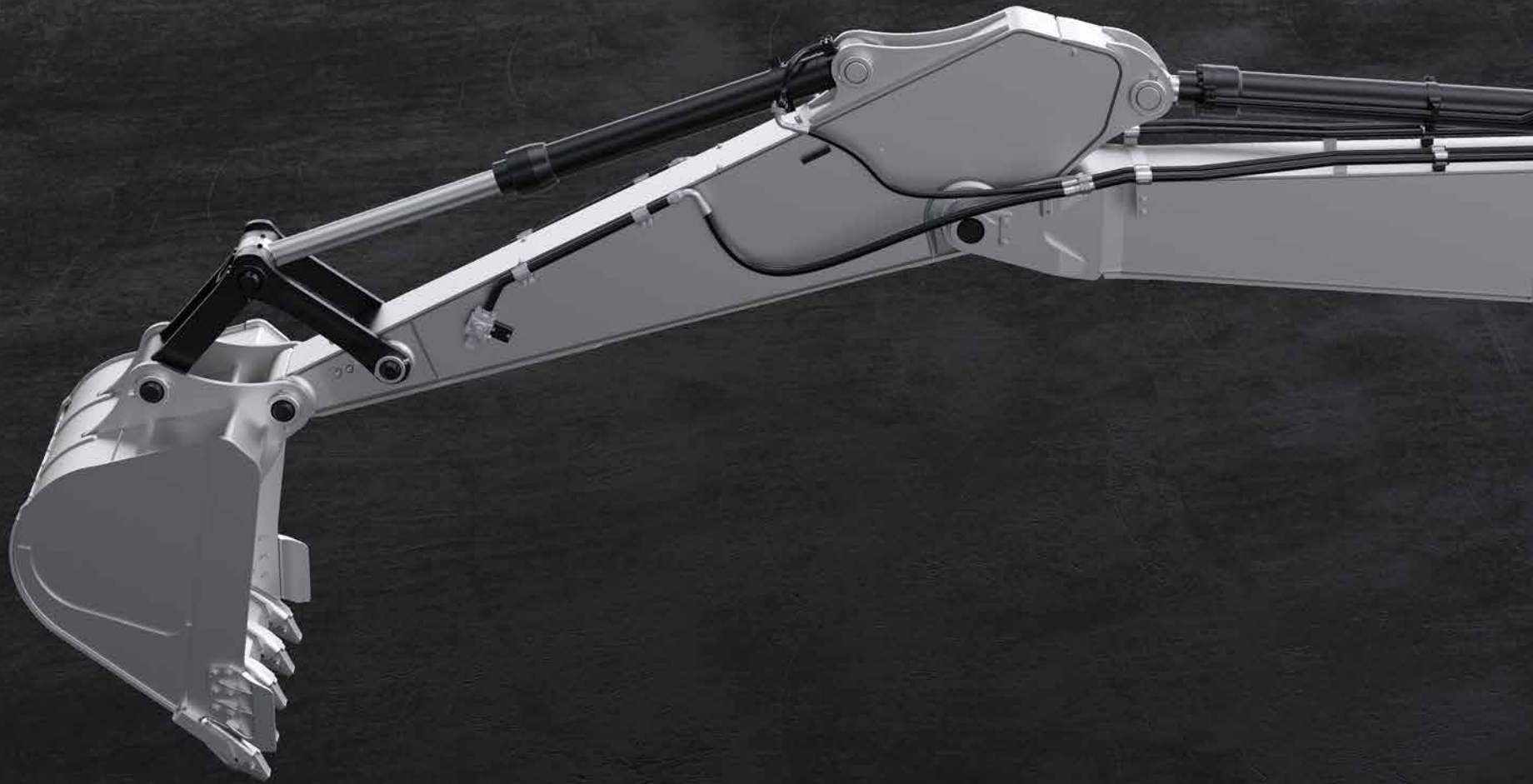

More durable

Produced to have reinforced heavy duty construction considering maximum performance, long life and smooth operation in severe field conditions, HÍDROMEK excavators ensure more durability with the improvements made in the new H4 Series.





①

More durable anti-wearing plates (Hardox 450 HB)



②

Optimized bucket form



③

Reinforced arm supporting parts



④

Reinforced casting tip



⑤

Reinforced boom cylinder cast bearing



⑥

Reinforced lowerframe and undercarriage components

Reinforced heavy duty construction

With their reinforced heavy duty construction produced at HİDROMEK's modern production facilities and going through sensitive quality-control processes, H4 Series excavators have excellent durability.

Bronze-Graphite Bushings



Bronze-graphite bushings used in boom-arm and boom-frame connection points increase the lubrication period, and greatly prevent the wear of the pins because of graphite, having a very high grease absorption and retention capability, embedded in the inner structure of the bushings.

④

①



Safe working environment

ROPS&FOPS2 cabin

Having the standards of ROPS (Roll Over Protective Structure) & FOPS2 (Falling Object Protective Structure), H4 Series excavators provide maximum safety and durability.

Wide vision capacity

Designed with giving special importance to occupational safety, H4 Series ensure excellent vision by minimizing the blind spot on the side and rear cameras. Along with the increase in the number of led headlights, the night vision is significantly improved on H4 Series excavators; in addition, there are also red handles and warning labels providing maximum safety for the operator.

Audio warning systems

H4 Series excavators enable safer working environment with their automatic starting horn, swing warning system and travel warning system.





Shaped with technology

Electronic system of H4 Series excavators designed to protect the engine and hydraulic components to provide fuel saving and superior performance.

Automatic stop system

In the new series, automatic stop system through configurable idling and stopping times provides fuel saving by stopping the engine after the machine is on idle. Automatic stop system in H4 Series helps to decrease the operational costs to minimum, and contributes to saving the environment.

Safe fuel transfer pump

“Safe fuel transfer pump” added to H4 Series stops the pump automatically when the tank is full and this feature gets activated also when the pump does not transfer fuel for 30 seconds, and ensures that the pump stops automatically.

Power boost technology

In H4 Series, power boost technology gets activated automatically in the conditions when the machine needs extra power, and ensures that the machine has the proper performance for the work.

8” Touch control panel

8 inch touch control panel is positioned ergonomically at a point that the operator can easily reach it. Touch control panel having high quality hardware and a large screen easily enables to control the machine features and access to machine information.

The features of touch control panel:

- It offers multi-language option
- Music system is integrated into 8” touch control panel.
- It allows the operator to adjust the flow required for the attachment without leaving the cab and save this information for 20 different attachments.
- During travel, rear and side view cameras with improved image quality and activated automatically can be controlled.
- Information on the average and instant fuel consumption can be obtained.
- Information on status such as atmospheric pressure, turbo boost pressure, fuel pressure and hydraulic pump pressure can be obtained.
- User can acquire working hour information such as work, attachment and travel.
- Maintenance registries can be obtained, and the user is warned when the maintenance time approaches.
- Failure codes and registries can be obtained.
- Audio warning systems can be controlled.





OPERA, the guide of the field

H4 Series excavators are equipped with Opera (HIDROMEK Operator Interface) for the operator to use the machine easily, and feel comfortable and relaxed as he is in an office environment.

Functions to be controlled by means of Opera

- Engine RPM control
- Access to control panel menu
- Functions of lights, windshield wipers and rear view camera
- Music system control
- Auto stop control of the engine to ensure maximum fuel economy during low idle
- On H4 Series machines, the preheating system available to protect the engine and hydraulic systems can be controlled via Opera.

The aesthetic design of power

The seat ergonomic, air suspended and having 35 degrees adjustable backrest angle is provided in H4 Series, and it enables the operator to work comfortably and without getting tired for long working hours.

H4 Series which has many features* such as proportional control pedals and joysticks, throttle control dial, operator touch screen, interior light, cup holder and heating-cooling box give more importance to user comfort.

HIDROMEK

* Other features for user comfort on H4 Series machines can be found on page 21.

Office comfort in construction equipment

Automatic air conditioning system

Air vents and air conditioning system which can automatically adjust itself according to the ambient heat located in the redesigned cabin provide the best cooling performance in its class by 30%.

Wide angle view

On the new series machines, the new two-piece windshield wiper system designed for creating more comfortable work environment provides a wide angle view which increases the work efficiency of the user.

Led headlights for night vision

Led headlights on new H4 Series machines improve the night vision, and enable the operator to work more safely and comfortably.

Dampers

By using 6 silicone dampers on H4 Series excavators, noise, shock and vibration are absorbed and prevented from being transmitted to the cabin under any working condition.



You have the control with HİDROMEK **SmartLink**

Telematic system HİDROMEK Smartlink allows the user to easily access to machine location and technical information via computer and mobile phone.

Follow the work time and location of your machine through HİDROMEK Smartlink!

Through GPS tracking system, it is possible to track the location and the work time intervals of the machine.

Analyze your fuel consumption through HİDROMEK Smartlink!

It is possible to analyze fuel consumption according to the working conditions of the machine and daily fuel parameters.

Check the works for which your machine has been used through HİDROMEK Smartlink!

Through working mode information, it is possible to see the daily and total working hours of the machine for excavation and leveling and with crusher or with other optional attachments besides the power mode information and the speed ranges.

Follow your machine's maintenance through HİDROMEK Smartlink!

Under the Alerts list, the machine's upcoming maintenance can be checked while the information of the nearest authorized service can be obtained, and it can be contacted.

Contact the nearest authorized service or regional service through HİDROMEK Smartlink!

With the application, it is possible to obtain the information on Regional and Authorized Services of HİDROMEK After Sales Services as well as the directions to them.

Have performance reports for the selected periods of time for your machines through HİDROMEK Smartlink!

For any selected periods of time, it is possible to have a report on daily fuel consumption, average fuel consumption, power and working modes, daily work time intervals and locations.



To download Smartlink application



Easy maintenance and fast service for H4 Series through safe and easy access

H4 Series excavators, designed considering fast access to hydraulic and engine equipment, provide easy maintenance and service. Most of the maintenance can be easily carried out without getting on the machine, which shortens the service time and increases machine work time.

Automatic greasing system ensures that all parts of the machine can be lubricated from one single center.



ENGINE

Brand & Model	ISUZU-6HK1X	
Type	Water cooled, 4 cycles, 6 cylinders, inline, diesel engine with direct injection, turbocharger and intercooler	
Power	Gross	281 HP (210 kW) @1900 rpm / SAE J1995
	Net	268 HP (200 kW) @1900 rpm / SAE J1349
Maximum Torque	Gross	1080 Nm @1500 rpm
Displacement	7790 cc	
Bore x Stroke	115 mm x 125 mm	
Emission Class	EU: Stage V	

HYDRAULIC SYSTEM

MAIN PUMP

Type	2 axial piston pumps with variable displacement and swashplate
Max. Flow Rate	2 x 290 L/min
Pilot Pump	Gear type, 28,5 L/min

WORKING PRESSURE

Attachment	350 kgf/cm ²
Travel	350 kgf/cm ²
Swing	285 kgf/cm ²
Pilot	40 kgf/cm ²

HYDRAULIC CYLINDERS

Boom	2 x ø 145 x ø 100 x 1.510 mm
Arm	1 x ø 170 x ø 120 x 1.735 mm
Bucket	1 x ø 145 x ø 105 x 1.280 mm

SWING SYSTEM

Swing motor	Fixed swashplate piston motor integrated with super shock absorber valve
Reduction	2 stage, planetary gear type
Swing Brake	Hydraulic disc type, pilot operated and automatically released
Swing Speed	9,3 rpm

LOWER FRAME

Construction	"X" type lower frame with pentagon shaped box type side frames
Shoe	Triple grouser
No. of Shoes	2 x 48 pieces
No. of Lower Rollers	2 x 8 pieces
No. of Upper Rollers	2 x 2 pieces
Full Trackguard	2 x 3 pieces
Track Tensioner	Hydraulic type with spring cushioning

ELECTRICAL SYSTEM

Voltage	24 V
Battery	2 x 12 V / 150 Ah
Alternator	24 V / 50 A
Starter Motor	24 V / 5 kW

TRAVEL AND BRAKES

Travel	Fully hydrostatic	
Travel Motor	Axial piston motor with 2 speed stages and swashplate	
Reduction	2 stage, planetary gear type	
Travel Speed	High Speed	4,9 km/h
	Low Speed	2,9 km/h
Max. Traction	30.740 kgf	
Gradeability	35° (%70)	
Parking Brake	Hydraulic disc type, pilot operated and automatically released	
Ground Pressure	0,72 kgf/cm ²	

FILLING CAPACITIES

Fuel Tank	565 L	Engine Cooling System	55 L
Hydraulic Tank	265 L	Engine Oil	44 L
Hydraulic System	470 L	Urea	70 L

OPERATING WEIGHT (kg)

	Mono Boom
HMK 360 LC	38.700
HMK 360 NLC	39.500

EQUIPMENT

HMK 360 LC

Engine	Standard	Optional
Water cooled diesel engine with turbocharger and intercooler	●	
Engine pre-heat function	●	
Automatic idling	●	
One touch auto-idle system	●	
Automatic stop function	●	
Two-stage air filter	●	
Air filter clogged indicator	●	
Low engine pressure warning system	●	
Overheat warning system	●	
Adjustable power modes	●	
High altitude working function	●	
Electronical engine control	●	

Hydraulic System	Standard	Optional
Boom and arm regeneration valve	●	
Automatic power boost	●	
Smooth boom feature		0
Main hydraulic filter	●	
Backup ports (valve)	●	
Cylinder cushioning and contamination seals	●	
Single-acting hydraulic line, breaker		0
Double- acting hydraulic line, crusher		0
Additional line		0
Quick coupling line		0
Attachment settings through instrument panel		0

OPERATOR'S CAB	Standard	Optional
Pressurized and sound isolated cabin	●	
Air-conditioning	●	
Air-suspension seat	●	
Air-suspended, heated, and seatbelt-warning seat		0
Heated seat		0
Operator touch screen	●	
Opera control system	●	
Throttle control dial	●	
Automatic travel speed (low / high)	●	
4 different working modes	●	
Sliding windscreen and removable lower windscreen	●	
Openable left door window	●	
Upper and lower windshield wiper	●	
Joysticks and pedals	●	
Travel pedals and control levers	●	
Proportional controlled pedals and joysticks		0
Electric horn	●	
Interior light	●	
Cup-holder	●	
Convenient storage	●	
Convenient storage (for equipment)	●	
Heating & Cooling box	●	
Easy-cleaned floor	●	
12V power socket	●	
Computer connection port	●	
Radio / mp3 / usb / Aux	●	
Detachable Movement Levers		0

Lower Frame	Standard	Optional
Lubricated track components.	●	
Mooring points for shipment	●	

Safety	Standard	Optional
ROPS (Roll Over Protective Structure)	●	
*FOPS2 (Falling Object Protective Structure)	●	
Rear view camera	●	
Side view camera		0
Right and left rear view mirrors	●	
Working lamps	●	
LED working lamps		0
Rotating beacon		0
Swing and travel alarm		0
Emergency engine stop switch	●	
Pilot operated and automatically released swing brake	●	
Boom and arm cylinder safety valve		0
Overload warning system		0
Battery cut-off switch	●	
Handrails by the steps and on the upper frame	●	
Perforated metal non-slip plates	●	
Safety locking device	●	
Safety glass	●	
Emergency hammer	●	
Lockable fuel tank cover	●	
Upper and lower guards for windshield		0
Fuel Safety System		0

Miscellaneous	Standard	Optional
Telematic system (HiDROMEK Smartlink)		0
GEO System		0
Fuel transfer pump with automatic stop	●	
Water sensor on fuel pre-filter	●	
Bio oil B7	●	
Alternator - Battery	●	
Battery Charge Indicator	●	
Automatic lubrication system		0
Working lamp guards		0
Hydraulic breaker return line filter		0
Double pump combination function		0
Choosing single or double acting attachment on the instrument panel		0
Choosing the control method for the optional attachment		0
Boom cylinder piping guard		0
Bucket cylinder rod guard		0
Warning horn	●	
Counterweights		0

● STANDARD 0 OPTIONAL

(*) FOPS2 upper cabin protection is standard in countries with CE requirements.

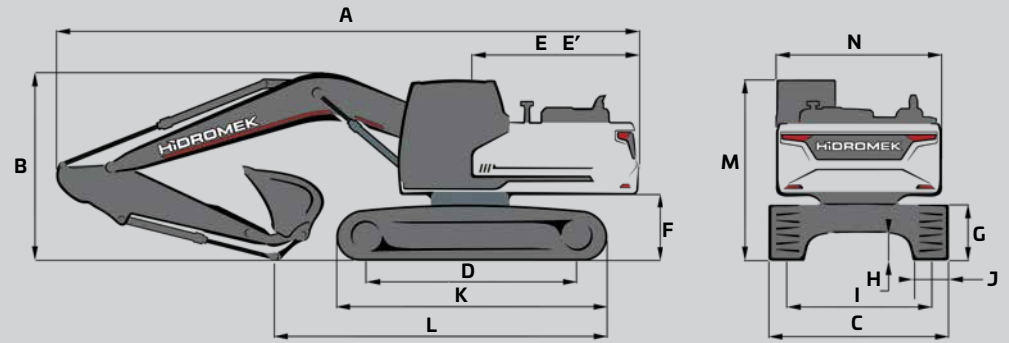
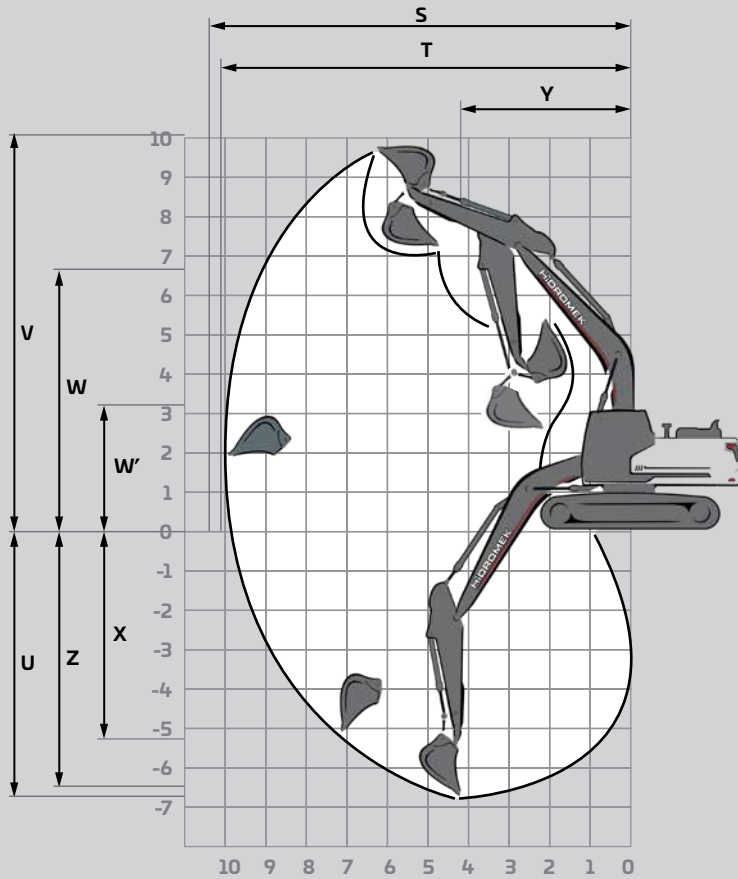

DIMENSIONS

		LC		
		Mono Boom		
BOOM (m)		6.50	6.50	6.50
ARM (m)		*2.60	3.20	4.0
GENERAL DIMENSIONS (mm)	A) Overall Length	11.420	11.380	11.460
	B) Overall height (to top of boom)	3530	3530	3730
	C) Overall Width	3300		
	D) Distance between tumbler	4040		
	E) Distance from center of swing to rear end	3540		
	E') Tail swing radius	3600		
	F) Counterweight Clearance	1250		
	G) Track Height	1090		
	H) Ground Clearance	505		
	I) Track Gauge	2700		
	J) Shoe Width	600		
	K) Track Length	4990		
	L) Length on ground (transport)	*6780	6110	5480
	M) Overall height of cab	*3190	3190	3330
N) Overall width of upperstructure	2990			
WORKING RANGES (mm)	S) Maximum Digging Reach	*10.720	11.340	12.050
	T) Maximum Digging Reach on Ground Level	*10.500	11.130	11.850
	U) Maximum Digging Depth	*6970	7580	8380
	V) Maximum Digging Height	*10.060	10.650	10.880
	W) Maximum Dumping Height	*6950	7310	7560
	W') Minimum Dumping Height	*3320	2720	7380
	X) Maximum Vertical Digging Depth	*5250	6720	4580
	Y) Minimum Swing Radius	*4480	4460	8240
Z) Maximum Digging Depth (2440 mm level)	*6770	7420	1930	

* Standard

FORCES

		LC		
		Mono Boom		
	BOOM (m)	6.50	6.50	6.50
	ARM (m)	*2.60	3.20	4.0
SAE	Bucket Digging Force	19.700	19.500	17.870
	Arm Crowd Force	19.400	16.100	12.610
ISO	Bucket Digging Force	23.200	23.100	21.045
	Arm Crowd Force	20.300	16.900	13.150

A- Material density less than 2.000 kg/m³
 B- Material density less than 1.800 kg/m³
 C- Material density less than 1.500 kg/m³
 D- Material density less than 1.200 kg/m³

* Standard

STANDARD BUCKET



DUAL RADIUS

	Width	1.650 mm
	Capacity (SAE)	*2,0 m ³
	Weight	1.850 kg
	Number of Teeth	5
ARM	2.60 m	B
	3.20 m	C

* Standard

OPTIONAL BUCKET SELECTION SCHEME

Excavation type bucket



Dump Truck Bucket



Dual Radius bucket



1.650 mm	1.800 mm	1.480 mm	1.150 mm	1.265 mm	1.400 mm	1.525 mm
1,80 m ³	2,0 m ³	2,1 m ³	1,20 m ³	1,40 m ³	1,60 m ³	1,80 m ³
1.750 kg	1.880 kg	1.785 kg	1.420 kg	1.515 kg	1.650 kg	1.735 kg
5	5	5	4	4	5	5
A	B	B	A	A	A	A
B	C	C	A	A	A	B

QUICK COUPLER



ATTACHMENTS

LIFTING CAPACITY (kg)													HMK 360 LC		
	Boom: 6.5 m		Arm: 2.6 m		Without bucket		STD, 600 mm Crawler		Shoe: 600 mm		CW: 6400 kg		📏 : Front	📏 : Side	
A, m	1,5		3,0		4,5		6,0		7,5		9,0		Maximum Reach		
B, m	📏	📏	📏	📏	📏	📏	📏	📏	📏	📏	📏	📏	📏	📏	R, m
9.0															
7.5													*8900	8450	7.10
6.0							*9650	*9650	*8850	7650			*8450	6800	8.04
4.5					*14150	*14150	*10900	10350	*9350	7400			*8750	5900	8.62
3.0							*12350	9750	*10050	7100			8250	5500	8.90
1.5							*13450	9250	*10450	6800			8100	5350	8.92
0 (Ground)					*18750	13650	*13900	9000	10250	6650			8350	5500	8.68
-1.5			*15500	*15550	*17750	13750	*13550	8950	10200	6600			9100	5950	8.15
-3.0			*20150	*20150	*15800	13950	*12250	9100					*9600	7050	7.27
-4.5			*15300	*15300	*12250	*12250							*9150	*9150	5.89

LIFTING CAPACITY (kg)													HMK 360 LC		
	Boom: 6.5 m		Arm: 3.2 m		Without bucket		STD, 600 mm Crawler		Shoe: 600 mm		CW: 6400 kg		📏 : Front	📏 : Side	
A, m	1,5		3,0		4,5		6,0		7,5		9,0		Maximum Reach		
B, m	📏	📏	📏	📏	📏	📏	📏	📏	📏	📏	📏	📏	📏	📏	R, m
9.0													*8250	*8250	6.54
7.5									*8050	7900			*7600	7300	7.85
6.0									*8200	7800			*7350	6050	8.71
4.5					*12800	*12800	*10150	*10150	*8800	7550	*8150	5600	*7400	5350	9.24
3.0					*16100	15100	*11700	9950	*9600	7200	8200	5450	7500	5000	9.51
1.5					*18350	14100	*13050	9400	*10350	6900	8050	5300	7400	4900	9.52
0 (Ground)					*18950	13700	*13800	9050	10300	6700	7900	5200	7550	5000	9.30
-1.5			*14550	*14550	*18450	13650	*13750	8950	10200	6600			8150	5350	8.81
-3.0	*17500	*17500	*22900	*22900	*16900	13800	*12900	9000	*9950	6650			*9000	6150	8.01
-4.5			*18500	*18500	*14050	14050	*10650	9250					*8850	7900	6.78

LIFTING CAPACITY (kg)
HMK 360 LC

	Boom: 6.5 m		Arm: 4.0 m		Without bucket		STD, 600 mm Crawler		Shoe: 600 mm		CW: 7400 kg		👉 : Front	👈 : Side	
A, m	1,5		3,0		4,5		6,0		7,5		9,0		Maximum Reach		
B, m	👉	👈	👉	👈	👉	👈	👉	👈	👉	👈	👉	👈	👉	👈	R, m
9.0									*6350	*6350			*6150	*6150	7.54
7.5													*5750	*5750	8.70
6.0									*7200	*7200	*7050	6250	*5600	*5600	9.48
4.5							*8900	*8900	*7900	*7900	*7350	6100	*5650	5100	9.97
3.0					*14100	*14100	*10550	*10550	*8800	7800	*7800	5900	*5850	4800	10.22
1.5					*17000	15500	*12150	10250	*9700	7450	*8300	5700	*6200	4650	10.23
0 (Ground)			*9050	*9050	*18450	14800	*13200	9750	*10350	7150	8350	5500	*6800	4750	10.02
-1.5	*9450	*9450	*13850	*13850	*18600	14550	*13600	9500	*10650	7000	8250	5450	7550	5000	9.57
-3.0	*14600	*14600	*19950	*19950	*17700	14550	*13250	9500	*10300	6950			*8200	5600	8.84
-4.5	*20700	*20700	*21800	*21800	*15700	14850	*11850	9650	*8900	7100			*8350	6850	7.75
-6.0			*15800	*15800	*11750	*11750	*8350	*8350					*8100	*8100	6.10

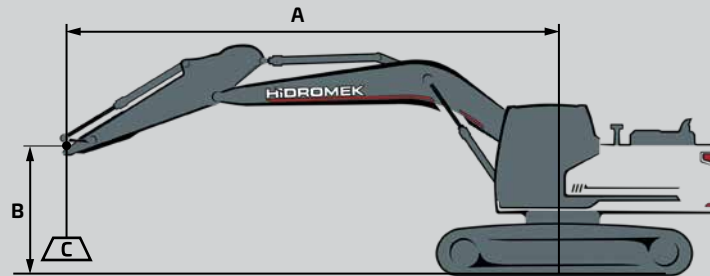

- A Load Radius
 B Load Point Height
 C Lifting Capacity
1. The above loads are in compliance with SAE J1097 and ISO 10567 Hydraulic Excavator Lifting Capacity Standards
 2. The load point is the center-line of the bucket pivot mounting pin on the arm
 3. Lifting capacity cannot exceed 75% of tipping capacity or 87% of hydraulic capacity.
 4. (*) indicates load limited by hydraulic capacity.

HİDROMEK®

HEAD OFFICE

Address : Ahi Evran OSB Mahallesi,
Osmanlı Caddesi, No:1, 06935
Sincan-ANKARA/TÜRKİYE

Phone : +90 312 267 12 60

Fax : +90 312 267 12 39

E-mail: export@hidromek.com.tr

AFTER SALES SERVICE

Address : İstanbul Yolu 17. Km,
Şehit Osman Avcı Mahallesi,
No: 479, Etimesgut-ANKARA/TÜRKİYE

Phone : +90 312 280 87 40

Fax : +90 312 280 87 48

HİDROMEK® WEST

HIDROMEK MAQUINARIA DE CONSTRUCCION ESPAÑA S.L.

Address : Avenida del Progrés, 7, 08840 –
Viladecans Barcelona/ SPAIN

Phone : +34 93 638 84 65

E-mail : info@hidromek.es

HİDROMEK® HCE

HİDROMEK Construction Equipment (Thailand) Ltd.

Address : Amata City Chonburi Industrial Estate Phase 7,
No. 700/669 Moo 1, T.Phanthong,
A.Phanthong, Chonburi 20160, TAYLAND

Phone : +66 38 447 349

Fax : +66 38 447 355

HİDROMEK® JAPAN

Address : 5-10, Hashimoto 6-chome,
Midori-Ku, Sagamihara,
Kanagawa, 252-0143 JAPAN

Phone : +81 42 703 0261

Fax : +81 42 703 0262

E-mail : Kiyoko.Shinoda@hidromek.com

HİDROMEK AROUND THE WORLD

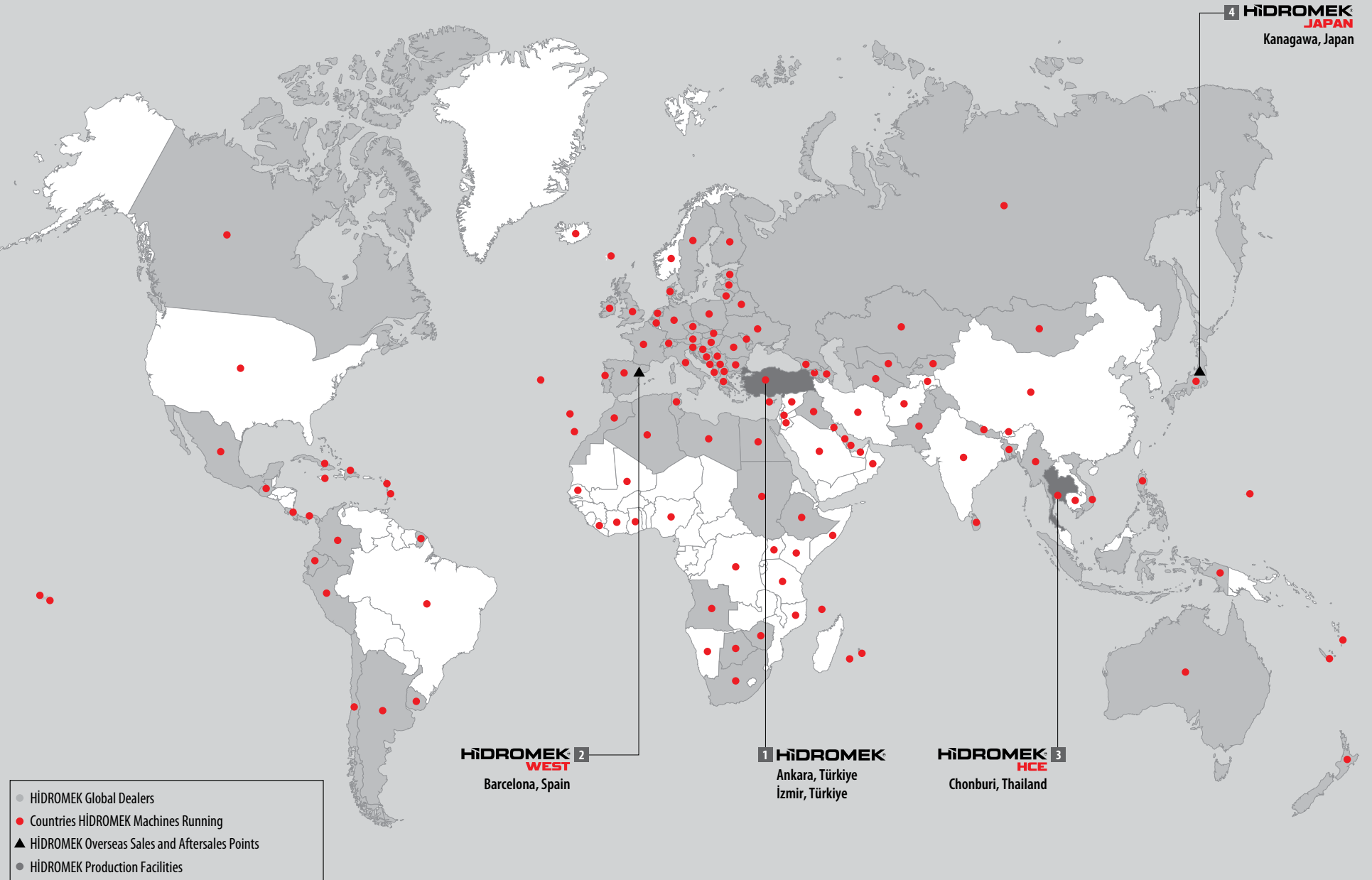

HIDROMEK®

Together Stronger

www.hidromek.com

 [hidromek.tr](https://www.facebook.com/hidromek.tr)  [Hidromek](https://twitter.com/Hidromek)  [hidromekofficial](https://www.instagram.com/hidromekofficial)  [HidromekTv](https://www.youtube.com/HidromekTv)  [company/hidromek](https://www.linkedin.com/company/hidromek)  [hidromek.official](https://www.tiktok.com/hidromek.official)

ENG - NOVEMBER 2025 / 181125 - Y

