



NEW!

ENGINE

Model	: ISUZU 6HK1X
Type	: Water-cooled, 4 cycle, 6 cylinders, line type direct injection, turbocharger, intercooler, electronic diesel engine
Power	: 264 HP (197 kW) @1900 rpm / SAE J1995 (Gross)
Max. Torque	: 1050 Nm @1500 rpm (Gross)
Displacement	: 7790 cc
Bore and Stroke	: 115 mm x 125 mm
Emission Class	: EU: Stage V

SUB-FRAME

X Type Lower Frame Construction Pentagon Box Type Chassis	
Shoe	: Triple grouser
No. Of Shoes	: 2 x 51 pieces
No. Of Lower Rollers	: 2 x 9 pieces
No. Of Upper Rollers	: 2 x 2 pieces
Full Trackguard	: 2 x 3 pieces
Track Tensioning	: Hydraulic Spring Tensioning

CAB

- Improved operator's all round visibility
- Increased cabin internal space
- Use of six viscomount cabin mountings that dampen the vibrations
- High capacity A/C
- High resolution, led backlight, color LCD display
- Opera Control System
- Cooled storage room
- Glass holder, book and object storage pockets
- Pool type floor mat
- Improved operator's comfort through versatile adjustable seat
- Ergonomically redesigned cabin through relocated switch board, and re-styled travel pedals and joysticks.
- FOPS2 upper cabin protection (Standard in countries with CE requirements).

TRAVEL AND BRAKES

Travel	: Fully hydrostatic
Travel Motor	: Axial piston motor with 2 speed stages and inclined plate
Reduction	: Planetary gear system with 2 stages
Travel Speed	
High Speed	: 5,1 km/h
Low Speed	: 3,0 km/h
Max Traction	: 25.460 kgf
Gradeability	: 35° (70%)
Parking Brake	: Hydraulic, disc type with automatic warning
Ground pressure (600mm)	: 0,61 kgf/cm ²

LUBRICATION

Centralized lubrication system is provided for lubrication all difficult-to-reach parts on the components, such as boom and arm

HYDRAULIC SYSTEM

Main Pump	
Type	: 2 axial piston type pumps with doublevariable displacement and inclined plate
Max. Flow Rate	: 2 x 266 L/min
Pilot Pump	: Gear type, 30,5 L/min
Working Pressures	
Cylinders	: 350 kgf/cm ²
Power Boost	: 380 kgf/cm ²
Travel	: 350 kgf/cm ²
Swing	: 285 kgf/cm ²
Pilot	: 40 kgf/cm ²
Cylinders	
Boom	: 2 x ø 135 x ø 95 x 1.455 mm
Arm	: 1 x ø 150 x ø 105 x 1.760 mm
Bucket	: 1 x ø 135 x ø 95 x 1.195 mm

OPERA CONTROL SYSTEM

- Easy-to-use control panel and menu
- Improved fuel economy and productivity
- Maximum efficiency by selection of power and work modes
- Overheat prevention and protection system without interrupting the work
- Automatic powerboost switch-on and switch-off
- Automatic electric power-off
- Maintenance information and warning systek
- Error mode registry and warning system
- Ability to adjust hydraulic flow from Opera screen
- Maintenance information and warning system
- Automatic powershift to improve performance
- Selection of multi-language on control panel.
- Real time monitoring of operational parameters such as pressure, temperature, engine load
- Anti-theft system with personal code
- Possibility to register 27 different operating hours
- Rear-view, arm-view camera (Optional)
- Hidromek Smartlink (Optional)

SWING SYSTEM

Swing Motor	: Axial piston type integrated with shock absorber valves
Reduction	: 2 stage planetary gear box.
Swing Brakes	: Hydraulic multi disc type, automatic warnings
Swing Speed	: 10,4 rpm

CAPACITY

Fuel Tank	: 475 L	Engine Oil	: 38 L
Hydraulic Tank	: 210 L	Engine Cooling System	: 55 L
Hydraulic System	: 395 L	Urea tank	: 70 L

ELECTRICAL SYSTEM

Voltage	: 24 V
Battery	: 2 x 12 V / 150 Ah
Alternator	: 24 V / 50 A
Starting Motor	: 24 V / 5 kw

WEIGHT

Standard machine operating weight : 32.200 kg
Operational weight, complying with the ISO 6016 standards, includes full fuel tank, hydraulic system and other liquids, 75 kg operator weight and standard equipped machine weight. Optional equipments are not included.

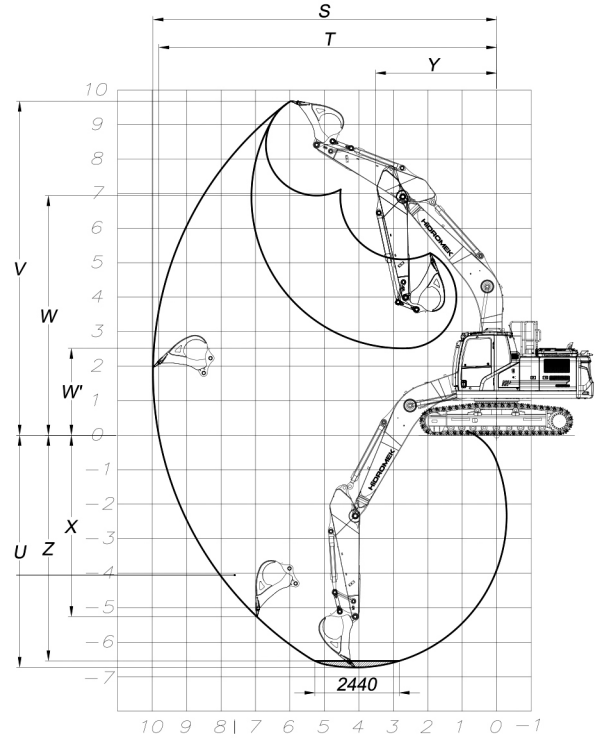
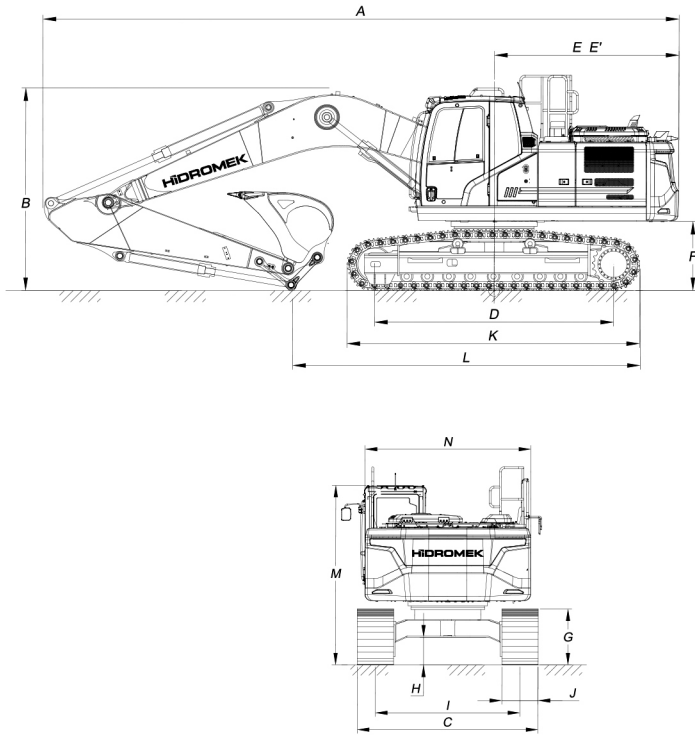

GENERAL DIMENSIONS

Boom Dimension	6.280 mm		
Arm Dimension	2.100 mm	*2.500 mm	3.070 mm
A - Overall Length	10.930 mm	10.880 mm	10.790 mm
B - Overall Height (to top of boom)	3.580 mm	3.490 mm	3.320 mm
C - Overall Width	3.200 mm		
D - Idler Distance	4.030 mm		
E - Counterweight Distance	3.235 mm		
E' - Turning Radius	3.255 mm		
F - Upper Structure Ground Clearance	1.205 mm		
G - Crawler Height	1.070 mm		
H - Minimum Ground Clearance	500 mm		
I - Track Gauge	2.600 mm		
J - Shoe Width	600 mm		
K - Overall Length of Crawler	4.950 mm		
L - Length Over Ground	7.540 mm	6.780 mm	5.860 mm
M - Overall Height (to Top of Cab)	3.140 mm		
N - Upper Structure Width	2.990 mm		

* Standard

WORKING DIMENSIONS

Boom Dimension	6.280 mm		
Arm Dimension	2.100 mm	*2.500 mm	3.070 mm
S - Maximum Digging Reach	10.020 mm	10.370 mm	10.910 mm
T - Maximum Digging Reach at Ground Level	9.790 mm	10.150 mm	10.700 mm
U - Maximum Digging Depth	6.360 mm	6.760 mm	7.330 mm
V - Maximum Digging Height	9.860 mm	9.990 mm	10.290 mm
W - Maximum Dumping Clearance	6.870 mm	7.020 mm	7.300 mm
W' - Minimum Dumping Clearance	3.790 mm	3.310 mm	2.760 mm
X - Maximum Vertical Digging Depth	4.890 mm	5.140 mm	5.780 mm
Y - Minimum Swing Radius	4.440 mm	4.360 mm	4.280 mm
Z - Maximum Digging Depth (2440 mm level)	6.140 mm	6.560 mm	7.160 mm

* Standard

DIGGING PERFORMANCE

Standard Bucket Capacity (SAE)	1,6 m ³
Bucket Digging Force (Power Boost) ISO	19.600 (21.300) kgf
Arm Crowd Force (Power Boost) ISO	16.400 (17.800) kgf

