

# HMK 635 WL



**HIDROMEK**





## HMK 635 WL, advantage of having more work with less fuel!

With **HMK 635 WL**, high efficiency, low fuel consumption!

**HMK 635 WL** fully meets the expectations of its users with the features such as high performance, versatility, operator comfort and safety. **HMK 635 WL** wheel loader is commonly used by quarry enterprises and concrete plants, for industrial applications and public services and in many fields with different attachments providing productive and efficient work possibilities. Heavy duty type loader **HMK 635 WL** offers high breakout power and excellent control capability in severe working areas.



Performance.....	6-7
Durability.....	8-11
Safety.....	12-13
Technology.....	14-15
Comfort.....	16-17
TIPSHIFT (FNR).....	18-19
Transmission.....	20-21
Loader Kinematics-Hydraulic System.....	22-23
Ease of Service.....	24-25
HiDROMEK Smartlink.....	26-27
Technical Features.....	28-31

The information and images, and equipment presented in this brochure are either standard or optional depending on the configuration. HiDROMEK has the right to modify the specifications and the designs of the model indicated in this brochure without prior notice.







## High Efficiency

HMK 635 WL produces more work with less fuel through its maximum power, high lifting capacity and breakout force, and offers high efficiency in every work with the advantage of loading in a short time.

## Fuel Saving

HMK 635 WL allows to work at desired power by consuming less energy with its high engine power. It saves fuel under all conditions owing to the high torque it provides even at low revolutions. Through the power-controlled pump used, HMK 635 WL provides easy breakout even at low revolutions without reducing the pressure of the pump when entering the load and when power is needed. Diesel engine, hydraulic pumps and transmission compatible with each other offer high performance under all operating conditions.

## Fast Cycle Time

HMK 635 WL increases productivity by shortening cycle times with its high unloading and optimum approach distances. It enables the work to be accelerated with its rapid movement capability for works that require traveling. HMK 635 WL provides easy usage with its high maneuverability while working in narrow areas due to its articulation angle of 40 °, and allows works to be completed in a short time.

# Heavy-duty HMK 635 WL: Powerful, durable, stable!

HMK 635 WL has excellent durability with its heavy-duty construction, which is produced with high technology at HİDROMEK's modern production facilities while going through sensitive quality-control processes.

- Heavy-duty axles and transmission offered as standard are high-strength and long-lasting.
- Sintered brake discs are long-lasting due to being heat and vibration resistant.
- Front and rear chassis and loader attachment group are made of high strength steel. In addition, the loader's durability to heavy loads, shocks and vibrations has been tested.
- Bucket blade, teeth and end blades are made of high-strength steel for tough working conditions.

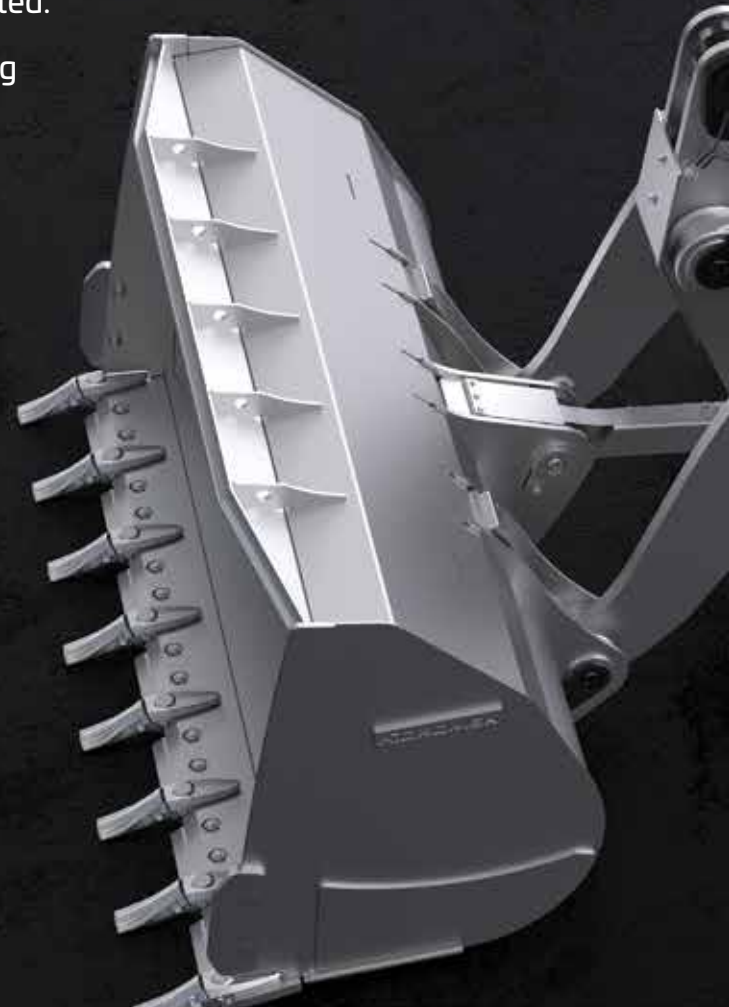



# Durable structure, long-life usage

The reinforced Z-bar of HMK 635 WL provides high breakout force. The bucket that has high-strength anti-wearing plates and body structure, increases the loading and carrying efficiency with its optimized form.

Heavy duty axle support and customized alloy bushings with superior slipping and lubrication properties, provide long-lasting use. Through a design suitable for working under heavy loads, HMK 635 WL offers excellent durability for long-term usage with the optimized boom, heavy-duty type front and rear chassis, reinforced bearings, reinforcements and Z-bar cast support.

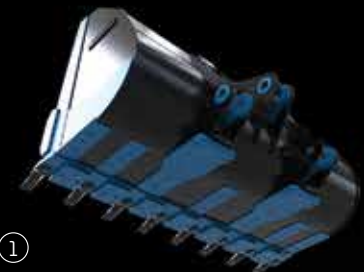

① Optimized bucket form, more durable anti-wearing plates and structure



⑤ Optimized boom, reinforced bushings, bearings, Z-bar cast support for long life usage



② Reinforced Z-bar mechanism boom suitable for high breakout force



⑥ Heavy duty bearings



③ Customized alloy bushings



⑦ Steering cylinders fully protected for heavy working conditions



④ Heavy duty front chassis designed for severe working conditions

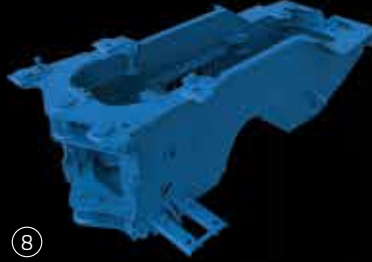

⑧ Heavy duty rear chassis designed suitable for severe working conditions

- ②
- ④
- ⑤
- ①





HIDROMEK

635  
HMK635WL

- 7
- 8
- 6
- 3

# SAFE WORKING ENVIRONMENT

## ROPS & FOPS cabin

HMK 635 WL has been carefully designed so that the operator can work in a comfortable environment even under the most severe conditions. It has ROPS/FOPS certification against overturning hazards and falling objects on the cab for the safety of the operator.

## Wide environmental view

While the reversing camera provides wide rear view to the operator during operation, the work lights on the cabin increase the environment vision capacity during night work. In addition, the user can adjust the mirrors at a desired angle from the cabin with the help of the button on the side console. The mechanism design of HMK 635 WL provides a wider viewing angle.

## Safe and Easy Usage

The following features of HMK 635 WL allow the operator to use the machine easily and safely; ergonomic red steps and handles that allow easy and safe access to the operator cabin by three points of contact, control lever lock that prevents unintentional movement of attachments, parking brake, electronically controlled heated mirrors, battery disconnect switch which is easily accessible from the ground to disable the electrical system in an emergency and some other safety equipment. Having the width of less than 3 meters, the machine can be transported easily and safely.





# Shaped with technology

## Control Panel

Touch control panel is positioned ergonomically at a point where the operator can easily reach. Touch control panel having high quality hardware and a large screen easily enables to control the machine features and access to machine information.

The features of touch control panel:

- Multi-language option
- Control of music system, USB, lighting system and air conditioning system
- Rear view camera control with increased image quality and activated automatically during travel and information on work lights
- Information on maintenance and working hours
- Information on transmission, engine and hydraulic system
- Automatic radiator cleaning frequency setting
- Machine idle standby time setting





## OPERA, the guide of the field

HMK 635 WL equipped with Opera (HIDROMEK Operator Interface) enables the operator to use the machine easily, and feel comfortable and relaxed as he is in an office environment.

Functions to be controlled by means of Opera

- Access to control panel menu
- Rear wiper and reversing camera functions
- Beacon lamps
- Fore arm Raising – lowering
- Automatic Bucket Positioning (RTD)
- Bucket Floating
- Music system control
- Engine start-stop control for fuel economy while idling
- MSS control
- Start/Stop function control
- Automatic Downshifting

# Every detail is designed with care

The features and equipment HMK 635 WL has highlight operator comfort and enable the user to work comfortably without getting tired for long working hours.

- Versatile holder on the console designed considering the operator's working environment and used for different purposes
- Pockets in different sizes and shapes at 2 different points behind the seat in the cabin and sections ideal for storage
- An ice box inside the cabin
- Ergonomically placed ventilation grilles in the cabin for providing a comfortable working environment to the operator and minimizing fogging on the windows.
- Dual-speaker AM/FM radio with USB input for long and enjoyable working hours
- 12 V power output to connect external devices
- Adjustable steering wheel for the desired angle and height
- The basic movements used while working in loading position are gathered on a console for operator's convenience

# Office comfort in construction equipment

## Fully automatic A/C system

Fully automatic A/C system providing a comfortable environment

## Panoramic cab with wide

Panoramic cab with wide field of vision and excellent insulation against noise

## Seat heating system

Seat heating system providing maximum comfort in cold weather conditions. Heated operator seat with air suspension adjustable to any desired position and according to the operator's weight

## Kick-down button

Kick-down button offering easy usage and used for downshifting



## TIPSHIFT (FNR) (Forward-Reverse Direction Control)

TIPSHIFT function enables to change the direction quickly by pressing a single key without using the gear lever when the machine is moving forward or backward while loading. This increases productivity and ensures safe operation without losing the control of the steering of the machine.



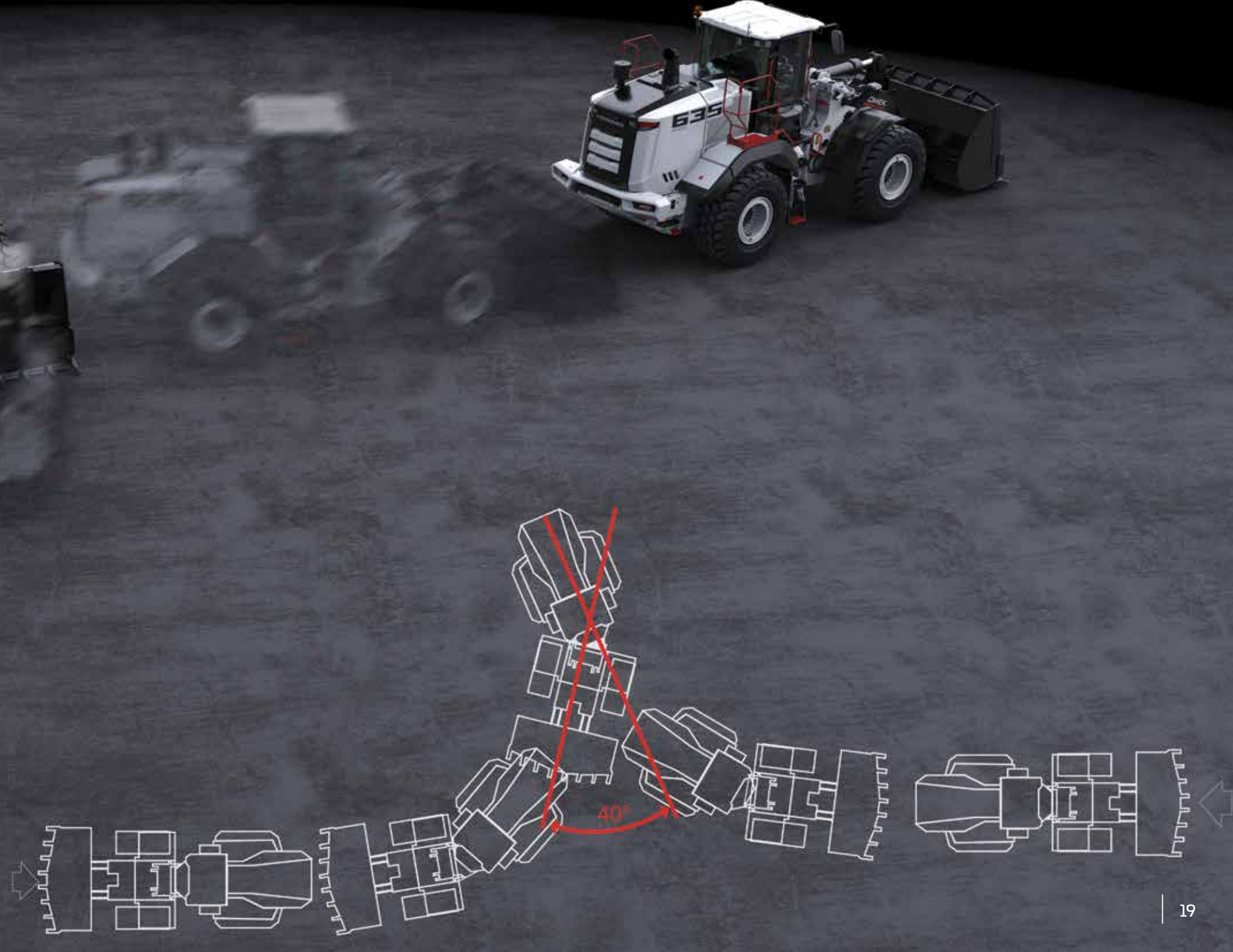

# Transmission

Thanks to the transmission control unit and full-compatible transmission software in the transmission of HMK 635 WL, shifting gears is performed very smoothly and rapidly. With the smart transmission disconnection (ICCO) feature provided in the system, when you press the brake pedal while loading and unloading, the power transmitted to the transmission is directed to the hydraulic system; as a result, the hydraulic power and the breakout force are increased. This increase is proportional to the rate at which the brake pedal is pressed. In addition, this feature reduces fuel consumption and increases the life of axle and brake systems.

With the automatic kick-down function, the machine shifts down a gear by only pressing a button while taking under a load, so the machine's traction force is increased, and the cycle time is shortened. Thus, HMK 635 WL increases efficiency in production processes.



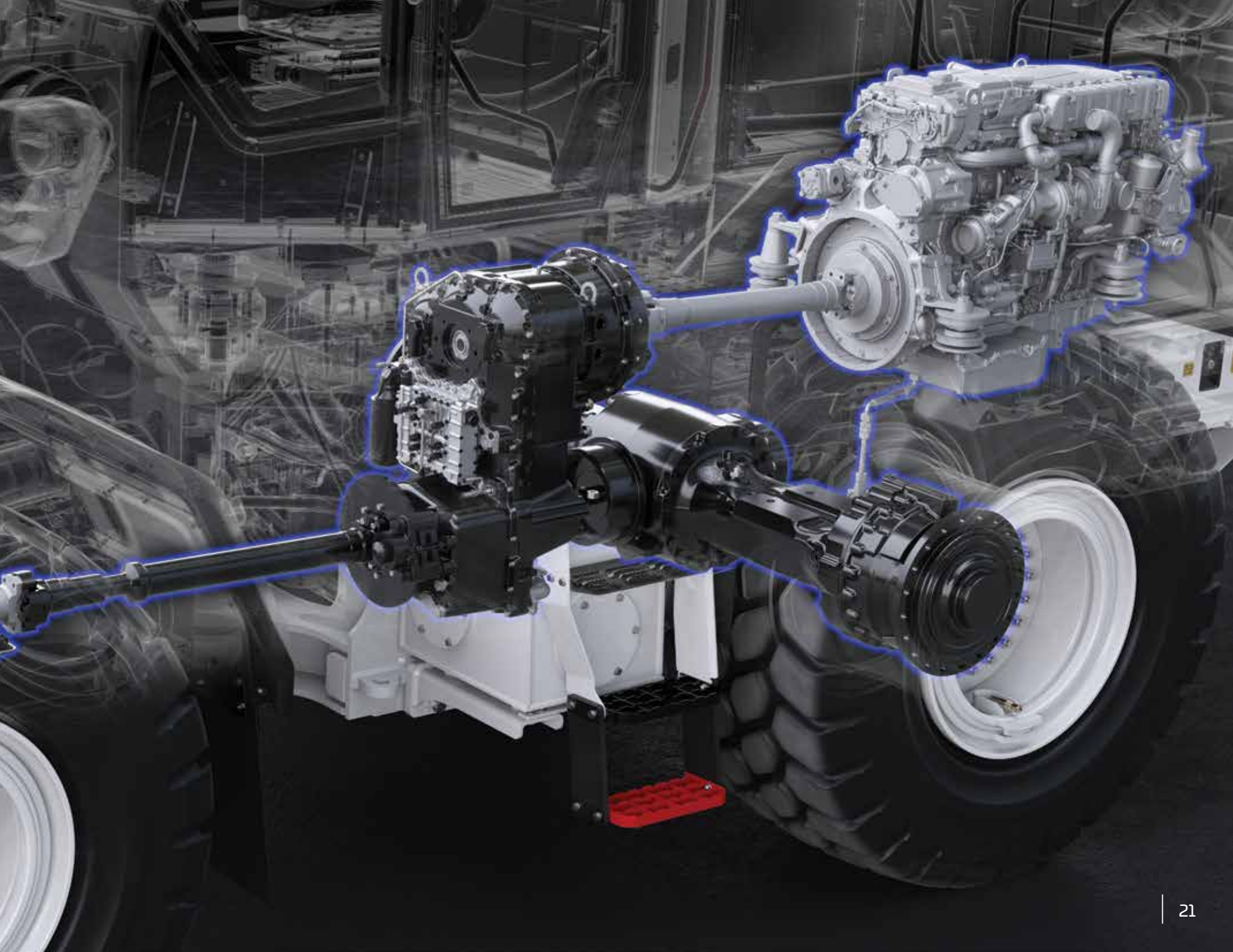

# Loader Kinematics

Z-bar connection significantly improves loading performance, breakout force, angle of view, and the fore arm and chassis resistance.

With the forearm automatic and bucket automatic functions, lifting arm and / or bucket can be adjusted automatically at a desired level allowing operator to focus only on the traveling function during loading. These features allow fast loading and increase production.

# Hydraulic System

A hydraulic system with closed loop load sensing feature and variable displacement piston pumps to operate the system are used. In this system, hydraulic flow and pressure loss are prevented since the amount of oil send is determined in accordance with the work done, and these minimized losses reduce fuel consumption. Vibration-free travel system, (MSS) protects the front boom from jolts and shock loads during travel. MSS minimizes vibration on the boom during travel when the bucket is loaded; therefore, it prevents falling of material, increases operator comfort and productivity.

Bucket movements of the machine can be controlled by electro-hydraulic control system with quick-response single-axis finger-type joysticks. Through automatic unloading, it does not get power from the engine while the bucket is unloaded and the boom is lowered, and this feature together with steering system's being hydraulic provides fuel saving.

\*Hand type joystick and MSS are optional.





# Fast maintenance and ease of service on HMK 635 WL with safe and easy access

HMK 635 WL offers easy access to service points on the machine from ground level, enabling fuelling up and battery maintenance operations to be performed easily. The cab may be manually tilted to 35° with a jack and the bonnet may be tilted to 80° with the aid of an electric actuator, which makes the access to the engine assembly easier.

The bonnet being opened as two pieces and having the engine and transmission groups located separately provides easy maintenance and service. Due to the tilting cabin offered as a standard, maintenance and repair can be done in a short time without being completely displaced.

Radiator cleaning can easily be done whenever it is required, thanks to the aerodynamic cooling fan reversed automatically or manually, if desired. This feature provides an advantage when working in dusty and covered areas. While it prevents the increase in fuel consumption caused by radiator contamination, it increases efficiency and allows radiator to be cleaned without manpower and extends maintenance intervals.

The pre-cleaner turbo filter located in front of the air filter and offered as a standard provides cleaner air and allows an increase in filter replacement time.

High-capacity and low-cost filters used on all of our product groups are widely available at reasonable costs.

HMK 635 WL enables the operator to follow the oil and fluid change times through the side panel and to alter the intervals if desired.

The fuse/relay panel is easily accessible from inside of the cab.

All these features enable easier maintenance and quick return to work.





# You have the control with HIDROMEK **SmartLink**

Telematic system HIDROMEK Smartlink allows the user to easily access to machine location and technical information via computer and mobile phone.

## **Follow the work time and location of your machine through HIDROMEK Smartlink!**

Through GPS tracking system, it is possible to track the location and the work time intervals of the machine.

## **Analyze your fuel consumption through HIDROMEK Smartlink!**

It is possible to analyze fuel consumption according to the working conditions of the machine and daily fuel parameters.

## **Check the works for which your machine has been used through HIDROMEK Smartlink!**

Through working mode information, it is possible to see the daily and total working hours of the machine for excavation and leveling and with crusher or with other optional attachments besides the power mode information and the speed ranges.

## **Follow your machine's maintenance through HIDROMEK Smartlink!**

Under the Alerts list, the machine's upcoming maintenance can be checked while the information of the nearest authorized service can be obtained, and it can be contacted.

## **Contact the nearest authorized service or regional service through HIDROMEK Smartlink!**

With the application, it is possible to obtain the information on Regional and Authorized Services of HIDROMEK After Sales Services as well as the directions to them.

## **Have performance reports for the selected periods of time for your machines through HIDROMEK Smartlink!**

For any selected periods of time, it is possible to have a report on daily fuel consumption, average fuel consumption, power and working modes, daily work time intervals and locations.



To download Smartlink application

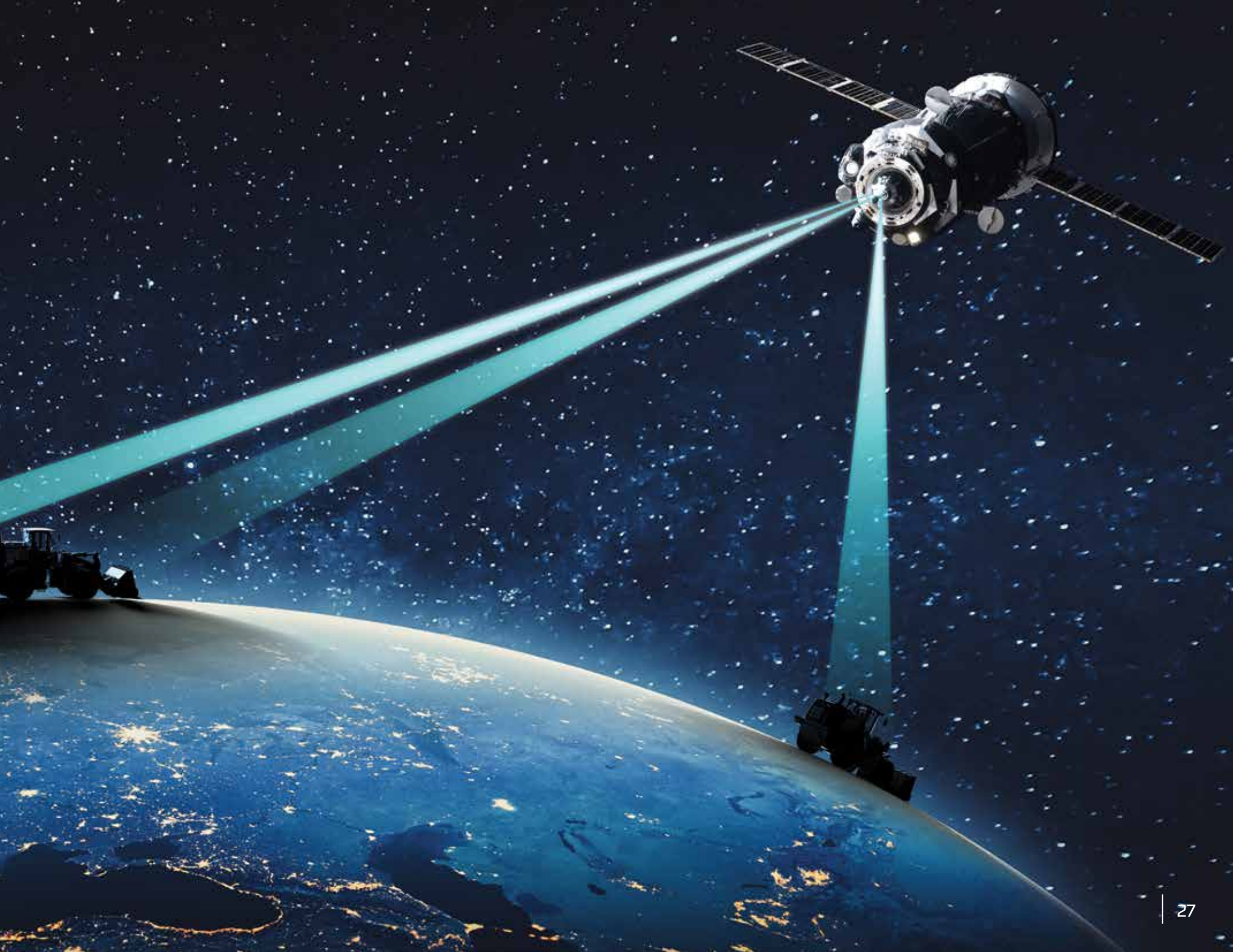

## ENGINE

Brand, Model	Mercedes-Benz MTU6R1000
Type	High power and torque output, water cooled, turbocharged diesel engine.
Number of Cylinders	6 in line
Bore x Stroke	110 mm x 135 mm
Volume	7700 cc
Max. Power	282 HP (210 kW) @1800 rpm
Max. Torque	1200 Nm @ (1200 - 1600 rpm)
Emission Class	EU: Stage V

## HYDRAULIC SYSTEM

Pump Flow	283 L/min @2100 rpm
Pressure	300 bar

Closed center type hydraulic system with LS type variable displacement piston type pumps

## TRANSMISSION

Auto Power Shift lock-up transmission, heavy duty type
5 forward and 3 reverse gears
4 Wheel Drive
Torque converter with 2.194:1 stall ratio
Start interlock when gear is engaged for safety purpose.

## AXLES

Heavy duty type axles
Planetary type reduction gears
Total 26 degrees oscillation on the rear axle
Equipped with differential lock on the front axle

## PERFORMANCE

Bucket capacity	3,6 m <sup>3</sup>
Max. breakout force	17650 kgf
Static tipping load (no tire deflection)	15900 kg
Static tipping load- articulated (no tire deflection)	14.000 kg

## DRIVING SPEED

1st gear forward	5 km/h
2nd gear forward	10 km/h
3rd gear forward	16 km/h
4th gear forward	25 km/h
5th gear forward	40 km/h
1st gear reverse	5 km/h
2nd gear reverse	10 km/h
3rd gear reverse	26 km/h

## FILLING CAPACITIES

Fuel tank	275 L
Hydraulic Tank	115 L
Hydraulic System	200 L
Engine Cooling System	40 L
Engine oil	28,5 L
Urea tank	40 L

## OPERATING WEIGHT (kg)

HMK 635 WL	20.600
------------	--------

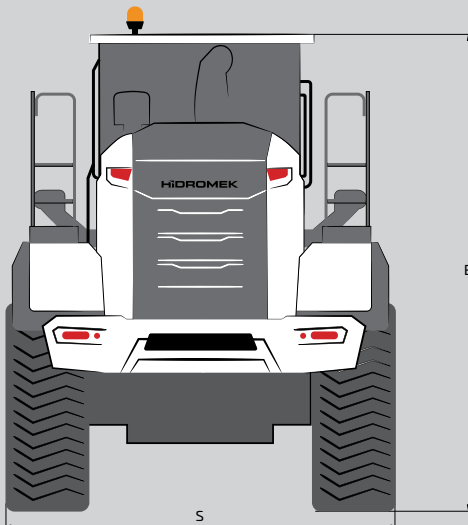
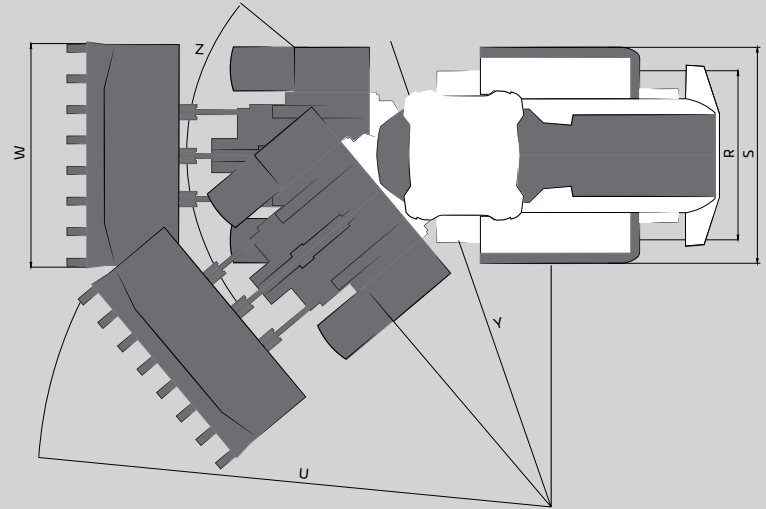
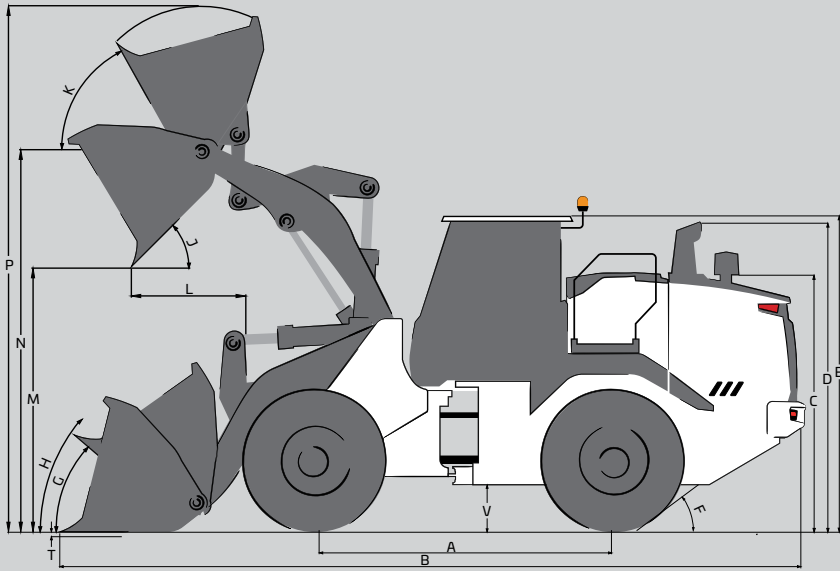

### GENERAL DIMENSIONS (mm)

A)	Wheelbase	3.300
B)	Total length	8.450
C)	Hood height	2.825
D)	Exhaust pipe height	3.375
E)	ROPS height	3.450
F)	Departure angle (°)	30°
G)	Rack back angle (°)	43°
H)	Max. Rollback(deg.) carry position (°)	48°
J)	Dump angle (°)	47°
K)	Max. Rollback at full height (°)	62°
L)	Dump distance with 26,5R25 L3	1.320
M)	Dump height	2.900
N)	Pin height @ dump	4.200
P)	Overall operating height	5.750
R)	Tread Width	2.200
S)	Width	2.800
T)	Dig Depth	100
U)	Turning radius - bucket	6.700
V)	Ground clearance with 26,5R25 L3	450
W)	Width of bucket	2.860
Y)	Turning radius - Tire outside	6.050
Z)	Turning angle (deg) (°)	80°

## EQUIPMENT

## HMK 635 WL

Engine	Standard	Optional
Water cooled diesel engine with turbocharger and intercooler	●	
EGR cooling system	●	
Air pre-cleaner, self-cleaning, heavy duty type	●	
High capacity two-staged primary and secondary air filter	●	
Automatic stop function	●	
Low engine oil pressure warning system	●	
Clogged-Air filter warning system	●	
Coolant level sensor	●	
Engine oil easy fill and remote drain	●	
Pre-fuel filter, water separator	●	
Temperature display and overheat warning system	●	
High altitude (2500m) working function	●	

Hydraulic system	Standard	Optional
Load sensing, variable displacement piston pumps	●	
Electro-hydraulic main control valve	●	
Electro-hydraulic joystick safety lock	●	
Automatic unloading system	●	
Boom and arm regeneration system	●	
Automatic Hydraulic pump power control system	●	
Return to Dig (RTD)	●	
Auto Boom lift	●	
Auto bucket Kick-out	●	
Reversible fan system, cooling and cleaning	●	
Electronically controlled proportional and bi-directional hydrostatic fan	●	
Dual brake circuit	●	
Dual brake pedal	●	
Main hydraulic and return filters	●	
Load-sensing, proportional auxiliary control valve		0
Quick coupler hydraulic line and valve		0
Load weighing system		0
Ride Control System (MSS)		0
Joystick steering system		0
Emergency steering system	●	
Electro-hydraulic parking brake	●	
Easy access for hydraulic pressure check ports	●	
Joystick with two proportional finger type controllers	●	
Joystick with three proportional finger type controllers		0
Proportional control joystick handle		0

Electrical And Lighting	Standard	Optional
24 V	●	
Batteries 2 x 12 V	●	
Alternator, 100 A	●	
Ignition key, start stop switch	●	
12 V outlet	●	
Reverse Alarm	●	

Safety	Standard	Optional
ROPS (Roll Over Protective Structure)	●	
FOPS (Falling Object Protective Structure)	●	
Rear-view camera	●	
Electronically adjustable and heated side mirrors	●	
Rotating beacon	●	
LED beacon lamp, rotating		0
Reverse Alarm	●	
Reverse gear light	●	
Emergency engine stop switch	●	
Battery cut-off switch	●	
Handles and handrails	●	
Non-slip step plates	●	
Emergency hammer	●	
Lockable fuel tank cover	●	
Special step system for service	●	
Windshield protection		0

Other	Standard	Optional
Telematic system (HIDROMEK SmartLink)		0
GPS		0
Bio diesel B7	●	
Alternator (24 V, 100 A) - Battery (2 x 12 V, 180 Ah)	●	
Battery Charge Indicator	●	
Automatic lubrication system		0
Working lamp protection cover	●	
Counterweights	●	
Fixing/lifting points for shipment	●	

● STANDARD ○ OPTIONAL

# EQUIPMENT

# HMK 635 WL

Cab & Hood	Standard	Optional
Widened visual angle	●	
Steering system with variable displacement	●	
Single key kit doors/start	●	
Tablet and phone holder	●	
35° tilting cab for service and maintenance	●	
Electrically 80° opening hood	●	
Halogen working lamps	●	
Led Headlights		○
Led Stoplights	●	
Led Working Lamps		○
Tool Box	●	
Electric horn	●	
Interior light	●	
Cup-holder	●	
Storage compartment	●	
Cooling box	●	
Floor mat, easy clean type	●	
Sun Visors	●	
Front and rear wipers	●	
12 V power socket	●	
Computer connection port	●	
Radio / MP3 / USB / AUX	●	
Openable door window and right window	●	
Adjustable joystick console and armrest	●	

Drivetrain	Standard	Optional
Fully automatic powershift transmission, heavy duty type	●	
Lock-up clutch transmission (optional)		○
Start interlock when gear is engaged for safety purpose.	●	
TIPSHIFT control	●	
26° oscillation on the rear axle	●	
Intelligent Clutch Cut-Off (ICCO)	●	
4 Wheel Drive	●	
100% hydraulic differential lock, manual	●	
Axle cooling and oil filtering system		○
Long life sintered brake disks	●	
23,5 R25 L3 tire	●	
23,5 R25 L5 tire		○
Powertrain protection guard	●	
Pressure check ports	●	

Linkage	Standard	Optional
Z-bar	●	
Auto-lift	●	
Return to Dig (RTD)	●	
Auto bucket kick-out	●	

● STANDARD ○ OPTIONAL





# HIDROMEK®

## HEAD OFFICE

**Address:** Ahi Evran OSB Mahallesi,  
Osmanlı Caddesi, No:1, 06935  
Sincan-ANKARA/TÜRKİYE

**Phone** : +90 312 267 12 60

**Fax** : +90 312 267 12 39

**E-mail:** export@hidromek.com.tr

## AFTER SALES SERVICE

**Address:** İstanbul Yolu 17. Km,  
Şehit Osman Avcı Mahallesi,  
No: 479, Etimesgut-ANKARA/TÜRKİYE

**Phone** : +90 312 280 87 40

**Fax** : +90 312 280 87 48

## HIDROMEK® WEST

### HIDROMEK MAQUINARIA DE CONSTRUCCION ESPAÑA S.L.

**Address:** Avenida Del Progres 7 08840 –  
Viladecans Barcelona/ SPAIN

**Phone** : +34 93 638 84 65

**E-mail** : info@hidromek.es

## HIDROMEK® JAPAN

**Address:** 5-10, Hashimoto 6-chome,  
Midori-Ku, Sagamihara,  
Kanagawa, 252-0143 JAPAN

**Phone** : +81 42 703 0261

**Fax** : +81 42 703 0262

**E-mail** : Kiyoko.Shinoda@hidromek.com

## HIDROMEK® RUS

**Address:** 72, Zhivopisnaya str, Building A,  
village Oktyabrskiy,  
Krasnodar, 350032, RUSSIA

**Phone** : +7 861 290 3007

**E-mail** : hidromekrus@hidromek.ru

## HIDROMEK® HCE

### HIDROMEK Construction Equipment (Thailand) Ltd.

**Address:** Amata City Chonburi Industrial Estate Phase 7,  
No. 700/669 Moo 1, T.Phanthong,  
A.Phanthong, Chonburi 20160, TAYLAND

**Phone** : +66 38 447 349

**Fax** : +66 38 447 355

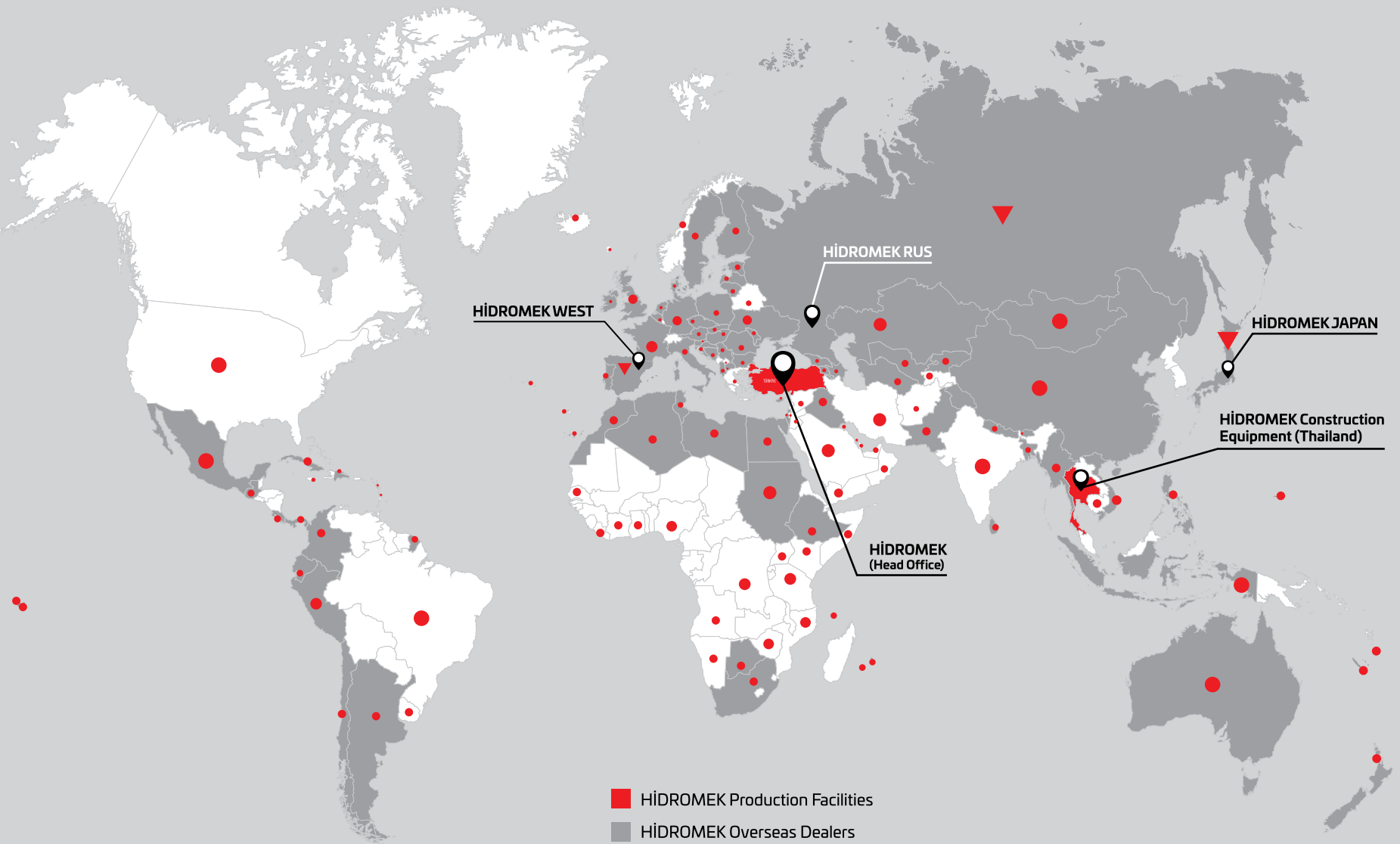

HÍDROMEK WEST

HÍDROMEK RUS

HÍDROMEK JAPAN

HÍDROMEK Construction Equipment (Thailand)

HÍDROMEK (Head Office)

- HÍDROMEK Production Facilities
- HÍDROMEK Overseas Dealers
- ▼ HÍDROMEK Overseas Sales and Aftersales Services Points
- Countries HÍDROMEK Machines Running

# HIDROMEK®

Together Stronger

[www.hidromek.com](http://www.hidromek.com)

 [hidromek.tr](https://www.facebook.com/hidromek.tr)  [Hidromek](https://twitter.com/Hidromek)  [hidromekofficial](https://www.instagram.com/hidromekofficial)  [HidromekTv](https://www.youtube.com/HidromekTv)  [company/hidromek](https://www.linkedin.com/company/hidromek)

ENG - OCTOBER 2023 / 101023 - V

